

CAD FILE:

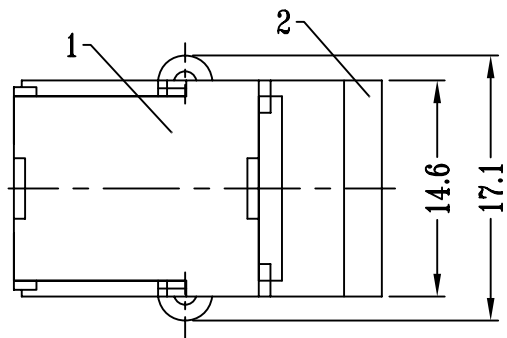

TIMING LAG DIAGRAM

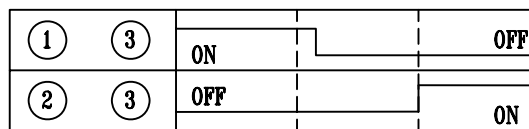

8.3 6.0

TRAVEL POSITION(X) (MM)

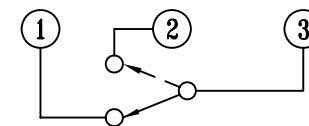

SCHEMATIC (NON-SHORTING)

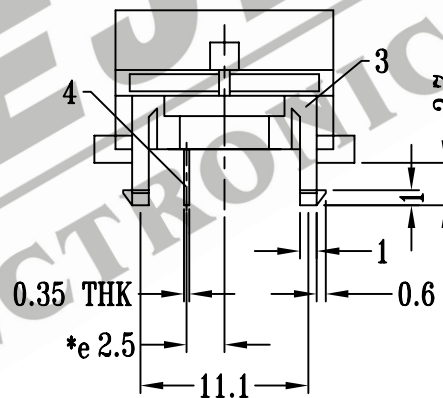
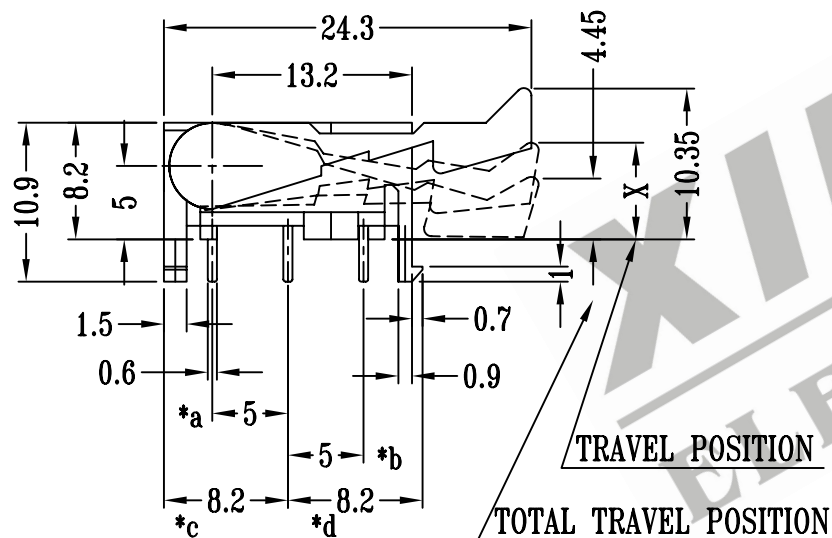

P.C.B.MOUNTING FACE
OPERATING FORCE: 50±20 gf

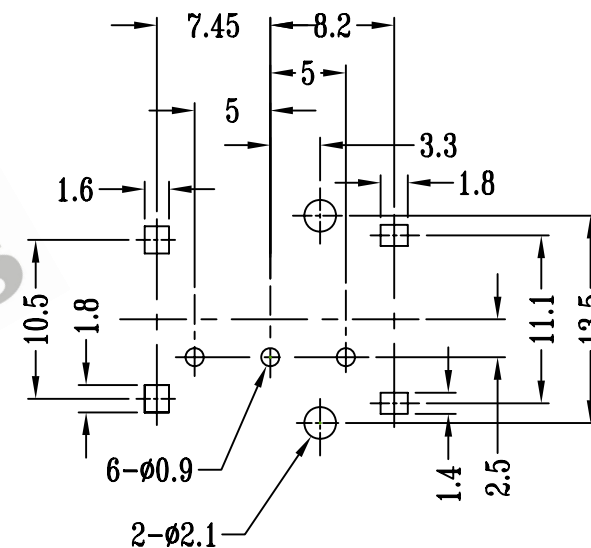

P.C.B. LAYOUT

注:带"*"表示关键尺寸(5个)

8	CONTACT (CLIP)	PBS	2	Ag PLATED	TOLERANCE UNLESS SPECIFIED	SHENZHEN XIEJIA ELECTRONICS CO.,LTD.				
7	SPRING	STEEL WIRE	1	TEMPER						
6	PRESS BAR	NYLON	1	GREY	WITHIN : 1.5±0.1mm	ISSUE	DATE	DESCRIPTIONS OF REVISION		APPD.
5	INSERT CASE	NYLON	2	WHITE	OVER : 1.5±0.2mm					
4	TERMINAL	BRASS STRIP	6	Ag PLATED OVER Ni PLATED	TITLE : HOOK SWITCH		UNIT : mm	DRWG NO.: XJ-DR-HS12L04-00		
3	CASE	NYLON	1	BLACK	MODEL: HS-12L04		SCALE: 1:1	DWN.	ZHOUYU	2005-10-23
2	KNOB	POM	1	WHITE	ALL MATERIALS MUST BE COMPLIANT TO ROHS			CHK'D	FANGYING	2005-10-23
1	COVER	POM	1	BLUE				APPD.	KANGXINAN	2005-10-23
NO.	PARTS	MATERIALS	Q'TY	FINISH						